

# MWV Specialty Chemicals Vapor Adsorber

SERIES  
500

## Specifications:

**Dimensions** – 5'5" x 3'4" x 7'

**Air Handling Capacity** – 500 cfm

**Particulate Removal Capacity** –

30% ASHRAE efficient pre-filter

99% ASHRAE efficient post-filter

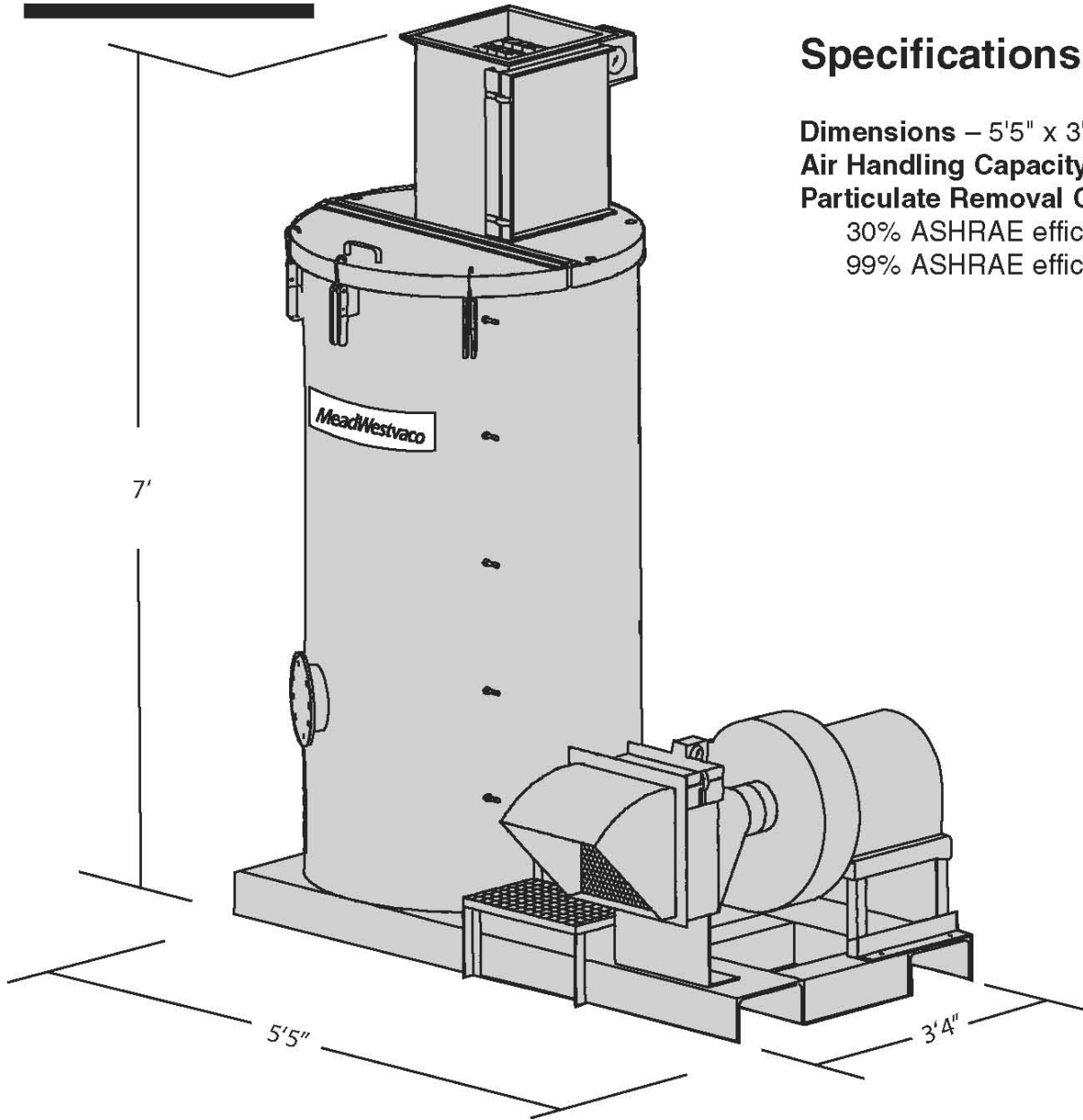

The MeadWestvaco Vapor Adsorber is a completely packaged, skid-mounted unit for the control of both organic and inorganic contaminants in gaseous streams...*by activated carbon adsorption and chemical reaction*. It was designed primarily to stop the harmful effects of low concentrations of corrosive gases in computer and electrical control rooms. It provides highly purified makeup air for pressurizing control rooms to prevent the intrusion of contaminated air. The unit is a pre-engineered system that includes air blower, pre- and post-filters and a deep-bed carbon adsorber, holding a special grade of NUCHAR<sup>®</sup> activated carbon. The carbon bed is designed so that it can be easily removed to facilitate servicing.

(OVER)

## Typical applications include:

- **Corrosion protection** – corrosive gases such as H<sub>2</sub>S, Cl<sub>2</sub>, ClO<sub>2</sub> and SO<sub>2</sub> can be removed from control room environments by treatment of make-up air with activated carbon...thereby protecting sensitive and expensive instrumentation and electronic components.
  - **Work area protection** – this carbon adsorption system can be used to remove from the environment organic and inorganic compounds which may be both toxic and unpleasant.
  - **Air pollution abatement** – off gases from manufacturing processes can be effectively purified in order to comply with Federal, State and Local air quality standards.
  - **Odor control** – this carbon adsorption system using NUCHAR® WV-IS carbon (specially treated to provide enhanced capacity for hydrogen sulfide) provides effective odor control.
- 

## Special features:

- **Skid mounted**
  - **FRP fan with 3 HP motor**
  - **Damper for flow control**
  - **Sample ports for monitoring pressure drop and contaminant breakthrough**
  - **Ease of carbon replacement**
  - **Materials of construction – FRP and stainless steel**
- 

## Activated carbon selection:

MeadWestvaco is a major producer of vapor phase pelletized activated carbons made from wood raw materials. From this family of products, a variety of carbons, exhibiting various adsorption characteristics, are available. This selection includes a carbon specially treated to provide a greatly enhanced capacity for chlorine and hydrogen sulfide removal. MeadWestvaco engineers and technical representatives can assist in the proper selection for your specific application.

For more information:

MWV Specialty Chemicals - Corrosion Technology Group

+1 (800) 348-7196